

802W Wideband HF COMINT System

The TCI Model 802W employs a flexible client-server architecture that provides a complete set of tools to carry out HF radio surveillance.

The system rapidly acquires and describes any traditional or modern HF signal activity, and subsequently performs detailed analysis of specific signals of interest. The 802W can carry out this analysis manually or automatically in real time or in delayed (post-facto) mode. The analysis includes detection, location, collection, classification and archiving of signal activities.

Under typical conditions the 802W system rapidly searches the HF spectrum using extremely fine resolution. When RF energy is detected, the system automatically determines the direction of the energy source and all other important signal parameters. This information is then automatically archived

for future analysis and can be simultaneously passed in real time to operator client workstations. The operator at a client workstation tasks the system to find a particular Signal of Interest (SOI) with specific parameters. The system then processes archived or real-time data to find the SOI and its geographic position or location and presents this information to the operator.

The foundation of the 802W system is high-speed signal search, combined with detection and direction finding obtained by simultaneous, parallel processing of multiple, 28 MHz-wide channels connected to an antenna array. The 802W is capable of performing automatic real-time DF analysis on any type of HF signal. The DF analysis provides transmitter parameters including frequency, direction and/or location, bandwidth, and time of transmission.

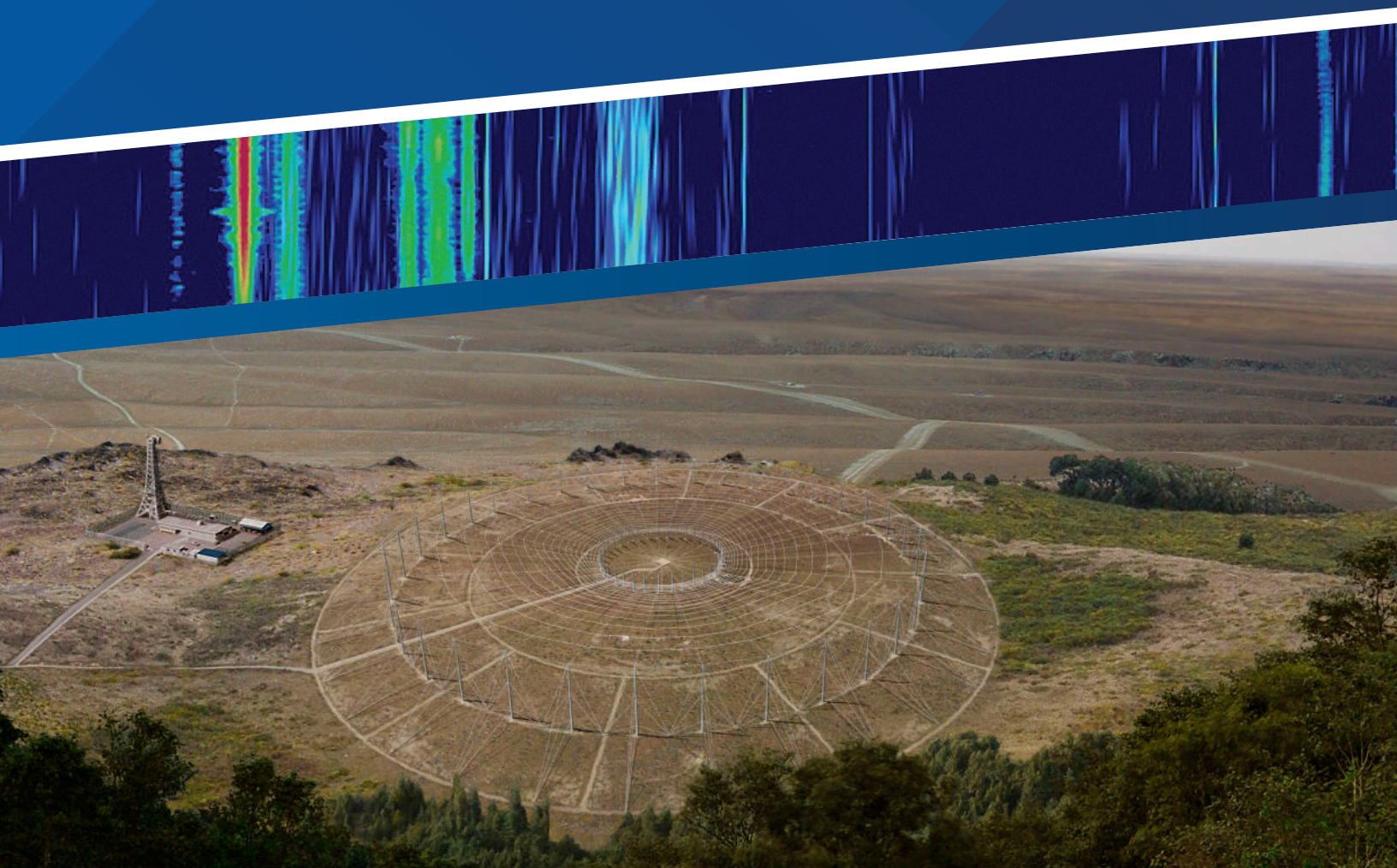

Depend on the field-proven solution for surveillance of traditional and modern HF signals.

THE VANGUARD OF HF DF

The established leader of field-proven HF DF COMINT technology with over 200 systems installed worldwide.

- > Pioneers of computer-based antenna design and Wavefront Analysis (WFA) DF, which is referred to today as correlative interferometry (CI).
- > Innovative use of large aperture circular disposed antenna arrays (CDAA).
 - » First WFA DF systems using CDAA delivered over 30 years ago.
- > Pioneers of N-channel HF DF architecture.
 - » First N-channel system delivered over 30 years ago.
- > Highest gain DF and monitoring antennas in production today.

KEY FEATURES

- > Manual and automatic HF signal detection, location, collection, analysis and archiving.
- > 2 MHz to 30 MHz frequency range (optionally down to .5 MHz depending on antenna type) with up to 28 MHz real-time bandwidth.
- > N-channel architecture, one receiver per antenna, is unsurpassed for dealing with the HF signal environment.
- > TCI DF First™ signal acquisition technology provides exceptional DF accuracy and speed.
- > High dynamic range and excellent co-channel frequency resolution.
- > Signal search and filtering by signal frequency, direction, location, duration, bandwidth and type.
- > Modular and scalable architecture for multi-user and/or multi-site applications operating 24/7.
- > Field-proven direction finding algorithms using TCI and non-TCI antenna arrays.
- > Archiving of measurement results including signal spectral activity, direction and location data.

OPTIONAL

- > Software interface libraries available for full integration with existing infrastructure.
- > Ionospheric sounder for real-time Single Site Location (SSL) processing.
- > DF Lookback recorder: Records multichannel IQ data for Post Facto DF processing.

FIGURE 1

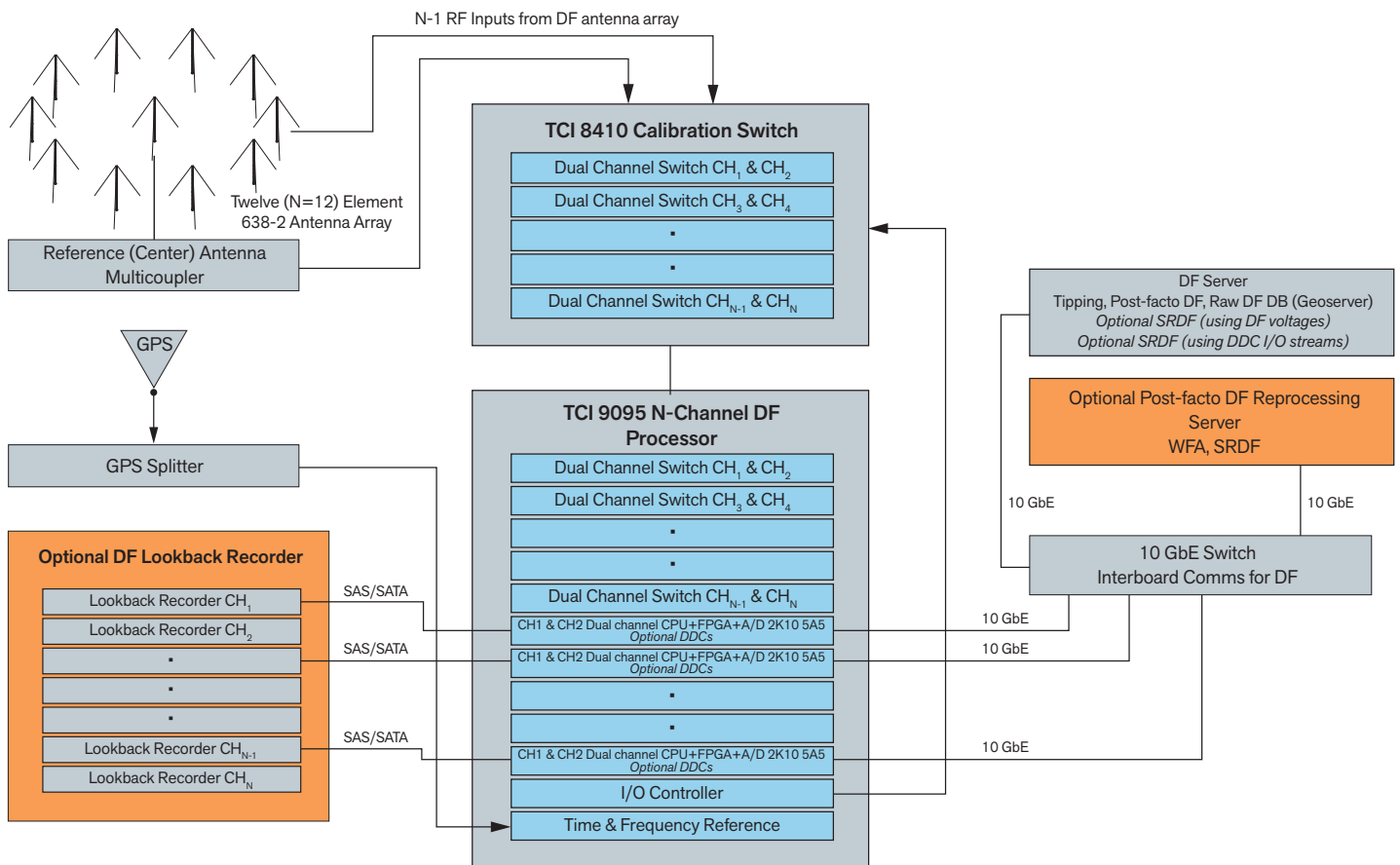

Subsystems Included

The 802W system consists of the following subsystems:

- › DF/Monitoring Antenna Array and RF Distribution
- › Wideband N-channel Signal Acquisition and DF Processor
- › Workstations for system tasking and manual real-time and post-facto signal analysis
- › Multi-site and external system interface

DF/Monitoring Antenna Array and RF Distribution

For direction finding, the 802W can be configured to operate with a variety of interferometer (I) and circular (C) antenna-array configurations using either TCI or non-TCI antennas:

- › 9-element array of TCI 632 whip antennas (I)
- › 9-element array of TCI 612 loop antennas (I)
- › 12-element array of TCI 632 whip antennas (C)
- › 24-element array of TCI 632 whip antennas (C)
- › 24-element array of TCI 638 whip antennas (C)
- › 12-element array of TCI 625 loop antennas (C)
- › 12-element array of TCI 638 whip antennas (C)
- › 20-element TCI 402 log-periodic antenna (C)
- › 24-element TCI 410 log-periodic antenna (C)
- › FRD-10 (C) (non-TCI)
- › FLR-9 (C) (non-TCI)
- › FRD-13 "Pusher" (singlet and doublet) (C) (non-TCI)
- › Turnstile (crossed-loops + whip) (C) (non-TCI)

Depending on the array type and its antenna-element count, either all or a subset of elements is used to achieve the optimal DF performance. The 'N' selected antenna elements (N varies between 8 and 14) are connected to a Signal Acquisition and DF Processor(s). For all array configurations an RF distribution subsystem ensures that the same antennas are used for both signal acquisition and DF processing.

Wideband N-Channel Signal Acquisition and DF Processor

The Model 802W uses N-channel architecture and an up to 28 MHz instantaneous bandwidth for high-speed simultaneous signal detection and DF. Field-proven, DF First™ technology optimizes performance, regardless of signal types or propagation conditions.

High instantaneous dynamic range and frequency selectivity (adjacent channel rejection) complement the N-channel architecture.

Each channel consists of a two module 2621 wideband HF preselector, a dual-channel high-speed digitizer and a digital signal processor (DSP). The 2621 filters an up to 28 MHz portion of the HF band that is fed to one of the channels.

i7 processors analyze all channels to a programmable resolution of 100, 125, 200, 250, 500, 1000, 2000, 2500, 5000 or 10000 Hz. The processors simultaneously detect signal activity in each channel and perform DF on active channels. Spectral, signal activity and DF data, are sent to the controller for further processing.

Signal Acquisition and DF Controller

Governing the operation of the Signal Acquisition and DF Processor(s) is a collection of software components running on a separate computer over a network interface. Controller functions include:

Client Access

The Controller manages clients' access to the DF processor(s). Management functions include consolidation of client tasking requests consisting of frequency ranges, signal detection and DF setup parameters.

Data Archiving

The Controller records the raw results, consisting of spectral, signal activity and DF data in a private local database. This database can store at least three days of raw data collected at the highest DF throughput rate. While raw data is archived, multiple clients can simultaneously retrieve

archived raw data. Data query results, filtered according to the client-specified criteria, are returned to client for emitter analysis.

Data Distribution

The Controller manages real-time distribution of raw data among the requesting clients via a network interface.

Signal Analysis

The Controller also maintains a signal activity list based on the raw data information.

Updated in real time, this activity list is available to any client on the network.

DF Lookback Recorder (Option)

The DF Lookback Recorder is based on Network Attached Storage (NAS) architecture where the recorder receives streaming wideband I/Q data over multiple 10 Gb Ethernet connections and writes it to disk using standard NTFS file system. While the I/Q data is written, it can be read simultaneously by multiple clients over a separate 1 Gb Ethernet network. NAS architecture enables a larger number of operators to simultaneously access the Post-Facto DF data. This implementation is illustrated in the system block diagram in Figure 1.

FIGURE 2

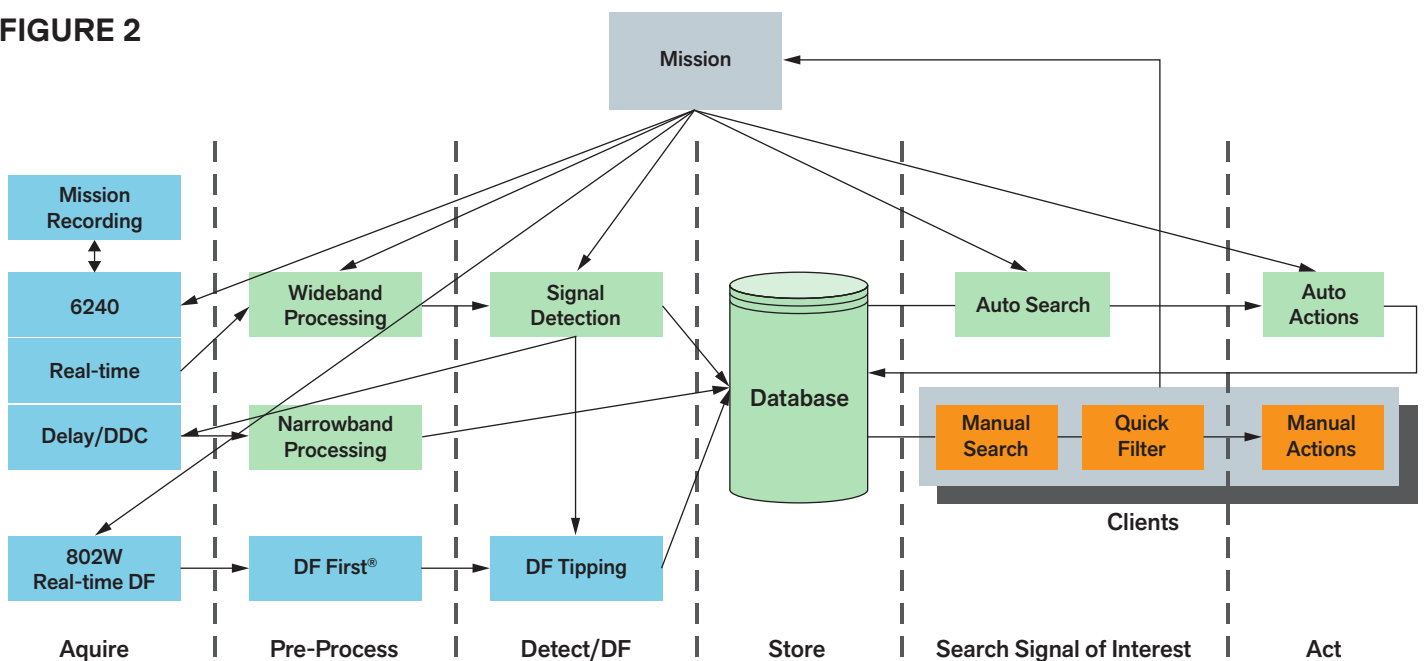

802W System Operation

Dashboard
View complete system status at a glance.

Search Pane
Select desired signal attributes and click Execute Search to launch the search.

Actions
Right click an intercept in the list, map or spectrogram to instantly access actions such as tagging, analysis and reporting.

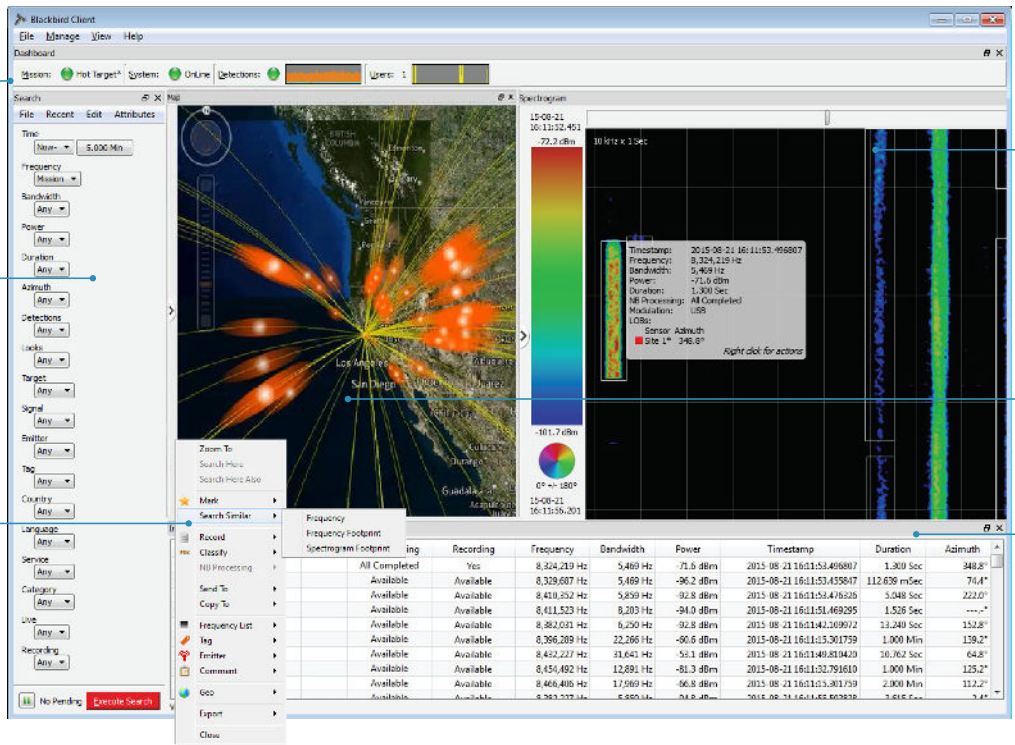

Spectrogram
View search results on spectrogram display. Point at any signal to pop-up the intercept info window. Zoom in / out and scroll back in time to see past signals.

Map
View search results on intuitive map display.

List
View search results in list format. Click column heading to select columns and sort.



Point and Shoot Simplicity

The new Blackbird's spectrogram display combines a traditional spectrogram view with an interactive detection database overlay. The unique, semi-transparent overlay shows detected signals from the realtime database. Simply point at any detected signal and a pop-up window shows the metadata for the intercept including any available modulation and DF results. It doesn't get any easier than that!

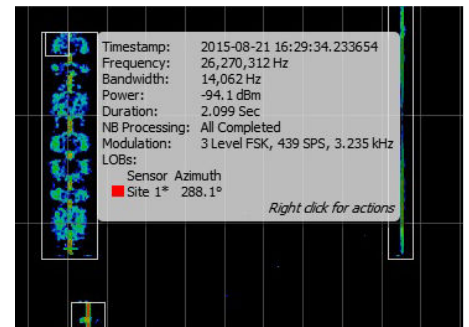

Redesigned from the Ground Up

The new TCI Model 802W Blackbird NextGen GUI has been completely reinvented from the ground up to provide the power of Blackbird with push-button simplicity. Since Blackbird is automatically detecting and cataloging all signal activity, the operator can browse all detections or search for specific signals of interest using the integrated list, spectrogram and map displays.

Search – Simplified!

To narrow the displayed results to only specific signals of interest, use Blackbird's easy to use Search pane to select the characteristics of the desired signals of interest. Or simply right click an intercept and use Blackbird's unique new Search Similar function to instantly find similar signals by frequency, spectral footprint or geolocation. No typing required!

Redefining Search and Visualization

Unlike traditional spectrogram views, the new Blackbird's spectrogram provides a unique, semi-transparent overlay showing the detected signal catalog.

Take Action

Once signals of interest are found, a simple right click opens the action menu. A variety of actions are available depending on loaded software options, including tagging, recording, Lookback Collection, modulation classification, AOA geolocation, and reporting. A "Send-To..." function instantly transfers the signal IQ data to signal analysis and decode tools; and a "Copy-To..." function exports the IQ data to external storage device or archive. The GUI also supports user-added custom actions to extend the analysis capability to instantly provide interoperability with external systems.

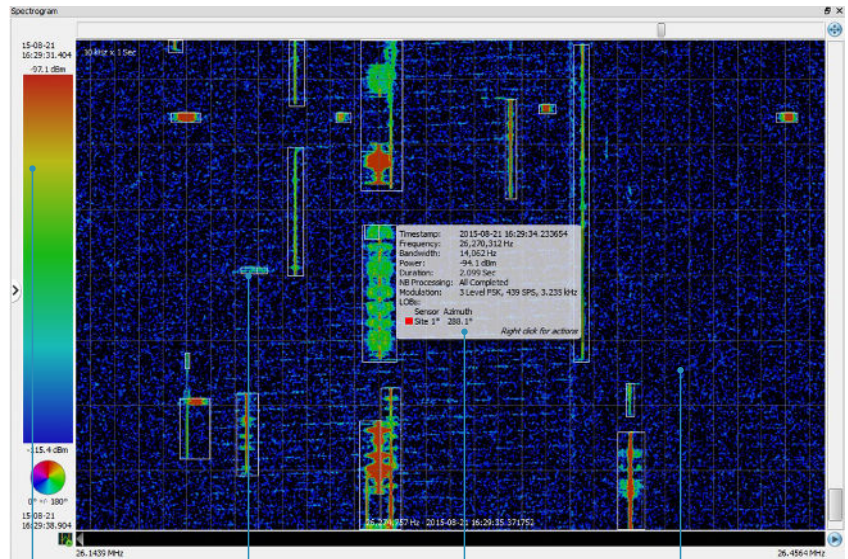
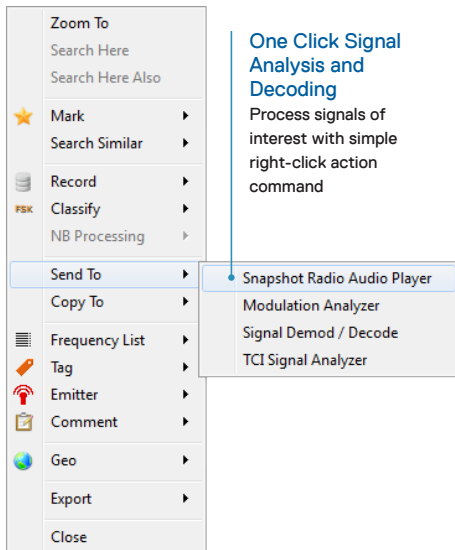

Color controls

Spectrogram data can be colored by power, direction or even tag.

Detection Overlay

Transparent overlay highlights detected signals.

Pop up Signal Info

Point at any detected signal to pop-up the signal info window. Right click to apply actions to the selected signal.

Spectrogram

Full spectrogram data served for live or past data.

Lookback Collection

When configured with optional Lookback Collection, you can not only view past signals, but you can collect them as well. Simply browse back in time or search for past signals of interest, then right-click to extract the signal's IQ data from the Lookback Storage Array. The new Lookback Storage Array allows IQ data to be extracted from the wideband recorder without interrupting recording. You'll never again miss a collect for a critical signal of interest.

classification, realtime or Lookback recording, Smart Recording (record based on signal modulation criteria), and AOA geolocation. Automation tasks can aid online operators with notification and alarms, or used to set up a completely automated search, collection and reporting mission — for unattended operation.

Time is on Your Side

Since Blackbird is automatically recording the spectral data along with the signal activity database, the operator can browse or search back in time (hours or even days) and view the past recorded spectral data with the detection database overlay. And since the spectral data is resampled and recorded at multiple zoom levels, zooming and panning with live or recorded spectrograms is fast...lightning fast!

Make it Automatic

Blackbird's easy to use Automation facility makes the collection task even easier. Simply click the Automate button after any search and choose your desired auto actions. Blackbird automatically evaluates incoming intercepts against the Automation search criteria. Matching intercepts will trigger automated actions such as operator alerts, tagging, automated modulation

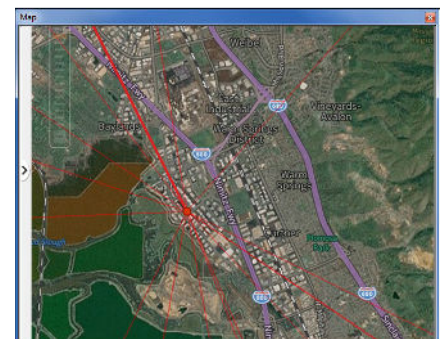

Search by Geolocation

When configured with TCI's Geolocation option, operators can define areas of interest to search for signals by geolocation.

Model 802W Specifications

| Antenna Array | |
|-----------------------------------|---|
| Nine element TCI 632 Array | Interferometer 5m monopole antenna 100x100 m deployment area |
| Nine element TCI 612 Array | Interferometer 2 m2 crossed loop antenna 100x100 m deployment area |
| Twelve element TCI 632 Array | Correlative Interferometer Circular Array r = 50m 5 m monopole antenna |
| Twenty-four element TCI 632 Array | 13 elements used Correlative Interferometer Circular Array r = 50m 5 m monopole antenna |
| Twenty-four element TCI 638 Array | 13 elements used Correlative Interferometer Circular Array r = 50m 12 m monopole antenna |
| Twelve element TCI 625 Array | Correlative Interferometer Circular Array r = 50m 10 m2 crossed loop antenna |
| Twenty element TCI 402 Array | 10 elements used + omni directional beam Correlative Interferometer Circular Array r = 107.5m Horizontal log-periodic antenna |
| Twenty four element TCI 410 Array | 12 elements used + omni directional beam Correlative Interferometer Circular Array r = 175m Horizontal log-periodic antenna |
| FRD-13 "Pusher" | 12 elements used + omni directional beam Correlative Interferometer Two Circular Arrays r = 25/75m 5/12 m monopole/monopole 5/12 m monopole/doublet |



| 2621 Receiver Specifications | |
|---------------------------------|---|
| Frequency range | 9 kHz to 30 MHz typical monitoring, 2 MHz to 30 MHz DF |
| Frequency tuning resolution | 1 Hz |
| Tuning Speed | 1 millisecond typical |
| Instantaneous bandwidth | Suboctave (1.75 to 5.25 MHz), 10 or 28 MHz |
| Number of channels | 8 to 14 |
| Analysis bandwidth | 100, 125, 200, 250, 500, 1000, 2000, 2500, 5000 and 10000 Hz |
| Signal Modulation | Any |
| Signal acquisition and DF speed | 2000 DFs/sec, typical |
| DF instrument accuracy | 0.1° RMS |
| DF Accuracy, Ground wave | 1° RMS |
| DF Accuracy, Skywave | 2° RMS, 1.5 to 30 MHz |

Specifications subject to change without notification.

Export of TCI International, Inc. systems and products may be subject to U.S. export controls. U.S. Export License may be required.

This document contains technical data whose export is restricted by the Arms Export Control Act (Title 22, U.S.C, Sec 2751, et seq.) or Export Administration Act of 1979, as amended, Title 50, U.S.C. App. 2401 et seq. Violations of these export laws are subject to severe criminal penalties.

continued on next page

continued from previous page

2621 Receiver Specifications (continued)

| | |
|--|---|
| SSL range accuracy with optional ionospheric sounder | 12% RMS, 200 to 1000 km emitter range ± 25 km, 0 to 200 km emitter range |
| Input impedance | 50 Ω |
| HF Bands | 3 kHz – 2 MHz, 2 – 3.75 MHz, 3.25 – 5.75 MHz, 5.25 – 8.25 MHz, 7.75 – 11.25 MHz, 10.75 – 15.25 MHz, 14.75 – 20.25 MHz, 19.75 – 25.25 MHz, 24.75 – 30 MHz, 2 -12 MHz, 10 – 20 MHz, 20 – 30 MHz, 2 – 30 MHz |
| AGC Range | 120 dB |
| Overall Gain | 60 dB in 2 dB steps (2 – 30 MHz) |
| Detection Modes | AM, FM, LSB, USB; CW for PM, PULSE and ISB |
| DF bearing resolution | 0.1° |
| DF azimuth coverage | 0-360° |
| DF elevation coverage | 0-85° (antenna type dependent) |
| DF Sensitivity | -44 dB μ V/m to -10 dB μ V/m, antenna dependent |
| Receiver in-band dynamic range | >85 dB |
| Input 2nd order intercept | +60 dBm |
| Input 3rd order intercept | +30 dBm |
| Receiver preselector filters | 8-band, sub-octave filters |
| Receiver frequency accuracy | 0.1 Hz |
| A/D resolution | 16 bits |
| Operating Temperature | -40° to +55° C |
| Operating Humidity | 0 to 95% |

Acquisition and DF Controller (typical configuration)

| | |
|---------------------------|--------------------------|
| Processor | Dual Xeon |
| Memory | 2 GBytes |
| Storage | RAID array, 250 GBytes |
| Operating System | Windows Server |
| Network | Gigabit Ethernet or 10GE |
| Raw Data Storage Capacity | 12 TB |

Workstations (typical configuration)

| | |
|-----------|-------------------------------------|
| Processor | Core i7 , 1 GByte RAM |
| Storage | 80 GBytes |
| Network | Gigabit Ethernet |
| Number | Limited only by the network submask |



TCI INTERNATIONAL , INC. 3541 Gateway Blvd., Fremont, CA 94538-6585 USA
 TEL: 1-510-687-6100 | FAX: 1-510-687-6101 | USA: 1-800-824-8074 | www.tcibr.com

